

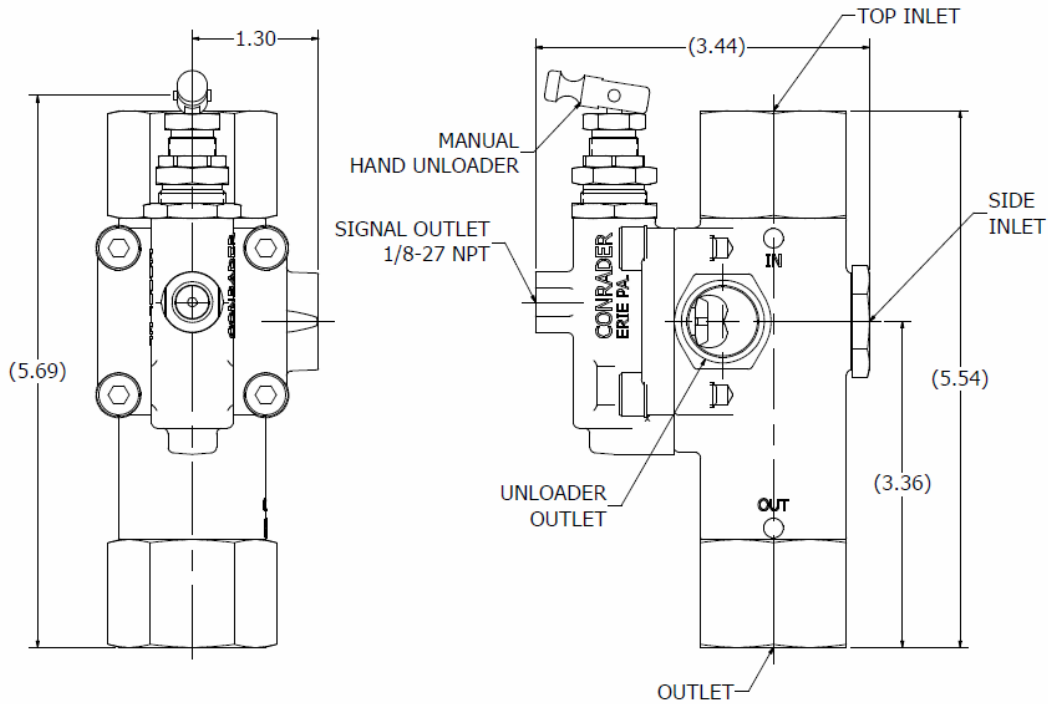

**Piloted Unloader Check Valve
Model: NLG-Series**



*Dimensions will vary with different connections and configurations.

Operating Specifications:

Unload Set Pressure Range: 40 to 250 psig

Set Pressure Differential Range: 10 to 50 psid

Operating Temperature Range: -65°F to 400°F

Max Flow Capacity: 60 SCFM @ 100 psig

Available Connections:

Connection Sizes: 3/4" to 1-1/4" (-12 to -20)

Connection Types: NPT, BSPT, Compression, Inverted SAE Flare

Materials of Construction:

Body/Fittings: Brass

O-Rings: Silicone/Viton

Poppets: Reinforced PTFE

Springs: Stainless Steel



Ordering Information

NLG		1		M		P1		HU2		SU3		SA		SST		90-120	
Configuration Number		Unloader Outlet		Additional Inlet Port		Hand Unloader Options		Start Unloader		Pilot Tamper Seal		Thread Sealant		Pressure Setting			
See Available Configurations Below		Option	Code	Option	Code	Option	Code	Option	Code	Option	Code	Option	Code	Option	Code		
		None (Standard)	(Blank)	None	(Blank)	Aluminum (Standard)	(Blank)	None	(Blank)	None	(Blank)	None	(Blank)	None	(Blank)		
		Muffler	M	1/8" NPT	P1	Red Cap	HU2	SU3	SU3	Sealed	SA	White	SST				
				1/4" NPT	P2	Black Knob	HU3	SU4	SU4								

Options

- Configuration: Available configurations are listed on the following pages. If the configuration needed is not listed please contact us at orders@conrader.com
- Unloader Outlet
 - Muffler: The muffler comes standard and reduces the noise from the unloader.
 - Diffuser: The diffuser restricts the flow less than the muffler but creates more noise.
- Additional Inlet Port
 - None: No additional port added.
 - 1/8" NPT: An 1/8" female NPT port installed on the opposite inlet port.
 - 1/4" NPT: An 1/4" female NPT port installed on the opposite inlet port.
- Hand Unloader Options
 - Aluminum: Standard aluminum hand unloader on all valves.
 - Red Cap: A red vinyl cap installed on the aluminum hand unloader.
 - Black Knob: A plastic black knob in place of the aluminum hand unloader.
- Start Unloader: A valve that installs on the opposite inlet port and unloads the compressor during start up.
 - None: Start unloader will not be installed.
 - SU3: Start unloader with a Viton seal.
 - SU4: Start unloader with a brass seal.
- Pilot Tamper Seal:
 - None: A seal will not be applied to the pilot adjustments.
 - Sealed: A blue tamper seal will be applied across the pilot adjustments.
- Thread Sealant:
 - None
 - White colored thread sealant.
- Pressure Setting: The desired pilot load and unload pressure settings.

Model	<u>Top Inlet Connection</u>	<u>Side Inlet Connection</u>	<u>Outlet Connection</u>
NLG-1	3/4" (-12) FEMALE NPT 3/4-14 NPT	NONE OR P1/P2 OPTION	3/4" (-12) FEMALE NPT 3/4-14 NPT
NLG-2	3/4" (-12) COMPRESSION 1-18 UNS-2A	NONE OR P1/P2 OPTION	3/4" (-12) FEMALE NPT 3/4-14 NPT
NLG-3	3/4" (-12) INVERTED SAE FLARE 1 1/16-16 UN-2B	NONE OR P1/P2 OPTION	3/4" (-12) FEMALE NPT 3/4-14 NPT
NLG-4	1" (-16) FEMALE NPT 1-11.5 NPT	NONE OR P1/P2 OPTION	3/4" (-12) FEMALE NPT 3/4-14 NPT
NLG-5			
NLG-6	3/4" (-12) FEMALE NPT 3/4-14 NPT	NONE OR P1/P2 OPTION	3/4" (-12) MALE NPT 3/4-14 NPT
NLG-7	3/4" (-12) COMPRESSION 1-18 UNS-2A	NONE OR P1/P2 OPTION	3/4" (-12) MALE NPT 3/4-14 NPT
NLG-8	3/4" (-12) INVERTED SAE FLARE 1 1/16-16 UN-2B	NONE OR P1/P2 OPTION	3/4" (-12) MALE NPT 3/4-14 NPT
NLG-9	1" (-16) FEMALE NPT 1-11.5 NPT	NONE OR P1/P2 OPTION	3/4" (-12) MALE NPT 3/4-14 NPT
NLG-10			
NLG-11	3/4" (-12) FEMALE NPT 3/4-14 NPT	NONE OR P1/P2 OPTION	1" (-16) FEMALE NPT 1-11.5 NPT
NLG-12	3/4" (-12) COMPRESSION 1-18 UNS-2A	NONE OR P1/P2 OPTION	1" (-16) FEMALE NPT 1-11.5 NPT
NLG-13	3/4" (-12) INVERTED SAE FLARE 1 1/16-16 UN-2B	NONE OR P1/P2 OPTION	1" (-16) FEMALE NPT 1-11.5 NPT
NLG-14	1" (-16) FEMALE NPT 1-11.5 NPT	NONE OR P1/P2 OPTION	1" (-16) FEMALE NPT 1-11.5 NPT
NLG-15			
NLG-16	3/4" (-12) FEMALE NPT 3/4-14 NPT	NONE OR P1/P2 OPTION	1" (-16) MALE NPT 1-11.5 NPT
NLG-17	3/4" (-12) COMPRESSION 1-18 UNS-2A	NONE OR P1/P2 OPTION	1" (-16) MALE NPT 1-11.5 NPT
NLG-18	3/4" (-12) INVERTED SAE FLARE 1 1/16-16 UN-2B	NONE OR P1/P2 OPTION	1" (-16) MALE NPT 1-11.5 NPT
NLG-19	1" (-16) FEMALE NPT 1-11.5 NPT	NONE OR P1/P2 OPTION	1" (-16) MALE NPT 1-11.5 NPT
NLG-20	1 1/4" (-20) FEMALE NPT 1 1/4-11.5 NPT	NONE OR P1/P2 OPTION	1 1/4" (-20) FEMALE NPT 1 1/4-11.5 NPT
NLG-21	1" (-16) FEMALE BSPT Rc 1-11 (BSPT)	NONE OR P1/P2 OPTION	1" (-16) FEMALE BSPT Rc 1-11 (BSPT)
NLG-22	3/4" (-12) FEMALE BSPT Rc 3/4-14 (BSPT)	NONE OR P1/P2 OPTION	3/4" (-12) MALE BSPT R 3/4-14 (BSPT)